



# Jaw type flexible couplings

## L-type



Coupling Size	Type	Bore Range	Outside Dia. "OD"	Hub Dia "A"	Overall Length "B"	Gap "C"	LTB "D"	Screw Size	Torque Rating in Lbs	Horsepower capacity at various "RPM"			
										100	1200	1800	3600
L035	1	1/4"-7/16"	5/8	5/8	13/16	9/32	17/64	6-32	3.5	0.006	0.07	0.10	0.20
L050	1	1/4"-5/8"	1 5/16	1 5/16	1 23/32	15/32	5/8	1/4"-20	26	0.042	0.50	0.75	1.50
L070	1	1/4"-3/4"	1 23/64	1 23/64	2	1/2	3/4	1/4"-20	42	0.070	0.84	1.23	2.52
L075	1	1/4"-7/8"	1 3/4	1 3/4	2 1/8	1/2	13/16	1/4"-20	90	0.140	1.68	2.57	5.04
L090	1	1/4"-1"	2 7/64	2 7/64	2 1/8	1/2	13/16	1/4"-20	144	0.230	2.76	4.11	8.28
L095	1	3/8"-1 1/8"	2 7/64	2 7/64	2 1/2	1/2	1	5/16"-18	144	0.310	3.72	5.50	11.10
L099	1	7/16"-1 3/16"	2 17/32	2 17/32	2 7/8	3/4	1 1/16	5/16"-18	318	0.500	6.00	9.00	18.00
L100	1	7/16"-1 7/16"	2 17/32	2 17/32	3 1/2	3/4	1 3/8	5/16"-18	417	0.660	7.90	11.90	23.75
L110	1	5/8"- 1 5/8"	3 5/16	3 5/16	4 1/4	7/8	1 11/16	3/8"-16	792	1.250	15.10	23.00	45.25
L150	1	5/8"- 1 7/8"	3 3/4	3 3/4	4 1/2	1	1 3/4	3/8"-16	1240	2.000	24.00	35.00	72.00
L190	2	3/4"-2 1/8"	4 1/2	4	5 1/4	1	2 1/8	1/2"-13	1726	2.700	32.40	49.00	97.00
L225	2	7/8"-2 3/8"	5	4 1/4	6	1	2 1/2	1/2"-13	2340	3.700	44.00	67.00	133.00

\* Torque ratings based on Buna-N rubber insert and service factor of one.

\* All dimensions are in inches.

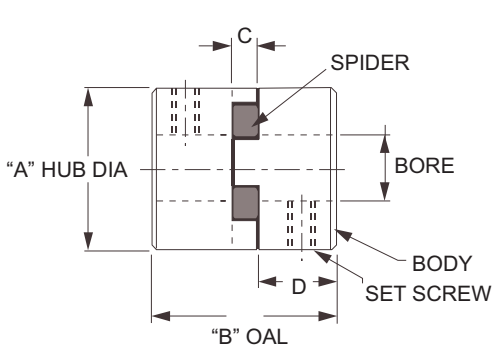

TYPE 1

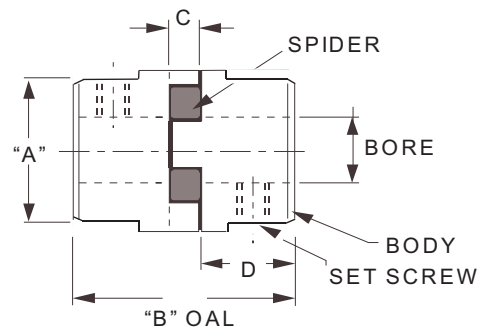

TYPE 2

### Product Data (Material)

All Types
L035, L050, L070 Sintered Steel
L075-L225 Iron cast GG25

### Standard Tolerances

Dimensions	Tolerance
Bore 3/16" to 2"	+0.001 / - .000
Bore 2-1/16" to 2-3/8"	+0.0015 / -.000



## Standard bore Keyway Chart

Bore	Keyway	LO35	L050	L070	L075	L090	L095	L099	L100	L110	L150	L190	L225
1/8"	No Keyway	X											
3/16"	No Keyway	X											
1/4"	No Keyway	X	X	X	X	X							
5/16"	No Keyway	X	X	X	X	X							
3/8"	No Keyway	X	X	X	X	X	X						
3/8"	1/8" x 1/16"		X			X							
7/16"	No Keyway	X	X	X	X	X	X	X	X				
7/16"	1/8" x 1/16"					X	X	X	X				
1/2"	No Keyway		X	X	X	X		X	X				
1/2"	1/8" x 1/16"		X	X	X	X	X	X	X				
9/16"	1/8" x 1/16"		X	X	X	X	X	X	X				
5/8"	3/16 x 3/32"		X	X	X	X	X	X	X	X	X		
11/16"	3/16 x 3/32"			X	X	X	X	X	X	X	X		
3/4"	3/16 x 3/32"			X	X	X	X	X	X	X	X	X	X
7/8"	3/16 x 3/32"				X	X	X	X	X	X	X	X	X
15/16"	1/4" x 1/8"					X	X	X	X	X	X	X	X
1"	1/4" x 1/8"					X	X	X	X	X	X	X	X
1 1/16"	1/4" x 1/8"						X	X	X	X	X	X	X
1 1/8"	1/4" x 1/8"						X	X	X	X	X	X	X
1 3/16"	1/4" x 1/8"							X	X	X	X	X	X
1 1/4"	5/16" x 5/32"								X	X	X	X	X
1 3/8"	5/16" x 5/32"								X	X	X	X	X
1 7/16"	3/8" x 3/16"								X	X	X	X	X
1 1/2"	3/8" x 3/16"									X	X	X	X
1 5/8"	3/8" x 3/16"									X	X	X	X
1 3/4"	3/8" x 3/16"										X	X	X
1 7/8"	1/2" x 1/4"										X	X	X
1 15/16"	1/2" x 1/4"											X	X
2"	1/2" x 1/4"											X	X
2 1/8"	1/2" x 1/4"											X	X
2 3/8"	5/8" x 5/16"												X
2 5/8"	5/8" x 5/16"												X

Spider Performance Data						
Type	Description	Temp Range	Misalignment Information		Dampening	Color
			Angular Deg.	Parallel Inch		
Buna N	Standard-Flexible	-40 C to +100C	1	.015"	High	Black
Urethane U	Higher Torque	-30 C to +70 C	1	.015"	Low	White
Hytrel H	High Torque & Heat	-50C to + 120C	1/2	.015"	Low	Brown
Bronze B	Rigid - Slow Speed	-40C to +230C	1/2	.010"	None	Bronze

Service Factors	
Load Type	Service Factor
Uniform Load - No Shock	1.00
Reversing / Uneven Load - Light Shock	1.75
Sudden Stops / Starts - Heavy Shock	2.50

Design Calculations	
Nominal Torque =	(HP x 63025)
(NM)	RPM
Design Torque =	NM x Service Factor